



Heat Pump Water Heater

SANCO2 
Hot water, *naturally.*



GEN4

SANCO₂

Available at: 888-470-2757

PEXHEAT.COM



As a highly energy-efficient alternative to the traditional electric or gas water heater, our unique system saves money, reduces greenhouse gas emissions and eliminates the production of carbon monoxide.

The SANCO₂ heat pump water heater system consists of two parts. The heat pump unit, where the hot water is produced, using the CO₂ refrigerant to extract heat from the ambient air, and the 43, 83 and 119 gallon storage tank.

43 Gallon Tank
69-Gallon first hour delivery

2 to 4 people

83 Gallon Tank
115-Gallon first hour delivery

5+ people

Superior Features

Highest First Hour Rating of any residential electric water heater (Resistance and Heat Pumps) provides more hot water.

Simple installation: only plumbing connections are required to connect storage tank and heat pump.

Faster recovery from a hot water draw at 20+ GPH of 150°F water to the top of the tank.

Heat pump will make hot water below -25°F to 104°F ambient temperature.

Highest real world efficiency: 80% savings over electric resistance water heaters and 40%+ over a hybrid HPWH.

Perfect for homes with Solar PV Panels as the unit will use less than 2,000 Watts maximum.

Most environmentally friendly water heater on the market: CO₂ refrigerant has a low global warming potential.

Longest and most comprehensive warranty on the market.

Technology – How It Works

- The SANCO₂ Water Heater works like any other storage water heater with one exception. The tank is stratified rather than mixed.
- Cold Water connections are located at the bottom of the tank and Hot Water connections are at the top.
- The Hot Water stored in the tank is hotter than Mixing Valve for normal use in the home or building. The unit is supplied with a Thermostatic Mixing Valve that must be installed to temper the delivered water to fixtures.

Energy Efficiency

The SANCO₂ unit works to maximize the UEF value not only in the test lab, but also in real world operation due to several of its unique features:

Inverter Compressor Inverter Compressors increase the efficiency of a heat pump by varying the speed of the compressor and hence the amount of electrical energy used.

DC Fan Motor & Water Pump The other motors in the SANCO₂, the fan and water pump, are also powered by direct current (DC), just like the Inverter Compressor. This allows both to run at a speed based on load requirements to optimize energy efficiency.

High Performance

The SANCO₂ unit has the highest UFHR (Uniform First Hour Rating) of any comparably sized Storage Electric or Heat Pump Water Heater.

The Natural Refrigerant (CO₂) used by the SANCO₂ allows it to make and store hotter water than any other Heat Pump Water Heater. This means there is more energy stored in the tank which translates into more hot water delivered via the factory supplied Mixing Valve.

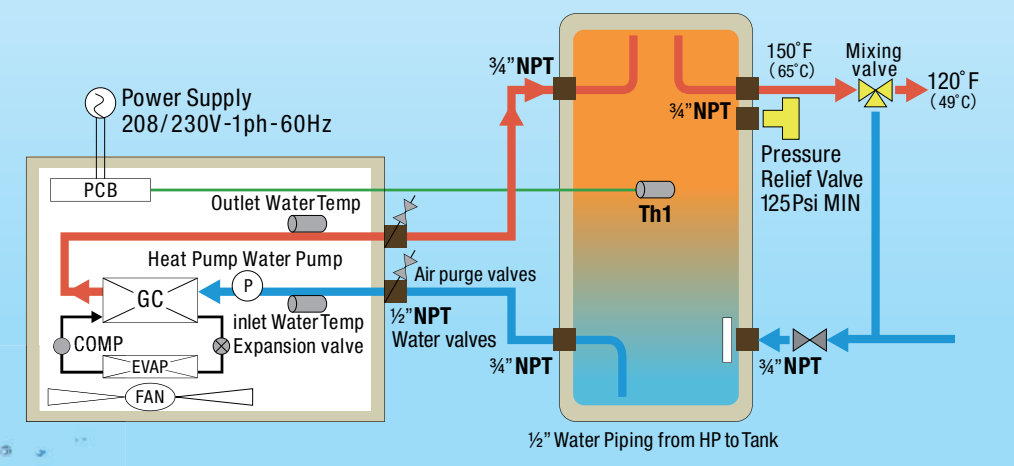

SANCO₂ GEN₄ Specifications

Heat Pump

All dimensions displayed in inches.

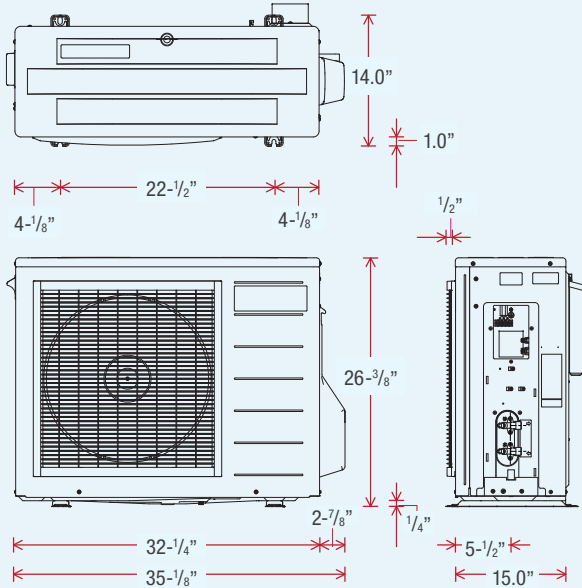

Outdoor Unit (Heat Pump) Model No. GS4-45HPC

| Performance | 43 Gal Sys | 83 Gal Sys | 119 Gal Sys |
|-----------------------|------------|-------------|-------------|
| Uniform Energy Factor | 3.1 | 3.75 | 3.4 |
| First Hour Rating | 69 gallons | 115 gallons | 135 gallons |

Specifications

| | |
|-------------------------------|--------------------------------------|
| Water Temperature Setting | 145 or 150°F |
| Ambient Air Operating Range | -25 to 104°F |
| Nom Heating Capacity (Btu/h) | 15,400 Btu/h |
| Nom Heating Capacity (kw) | 4.5kw |
| Heating COP @80/47/17°F | 5.5 / 4.2 / 2.8 |
| Refrigerant Type | R744 (CO ₂) |
| Power Voltage | 208/230v-1Ph-60Hz |
| Breaker Size | 15 Amps |
| MCA (Amps) | 7.2 Amps |
| Compressor Type | Rotary |
| Noise Level (DbA) | 37 |
| Weight (lbs) | 108lbs |
| Pipe Size (Tank to Heat Pump) | 1/2" (Both Hot Supply & Cold Return) |
| Max Length inc Vertical Sep | 66 ft |
| Max Vertical Separation | 23 ft |
| Max Incoming Water Pressure | 95Psi |

Stainless Steel Storage Tank*

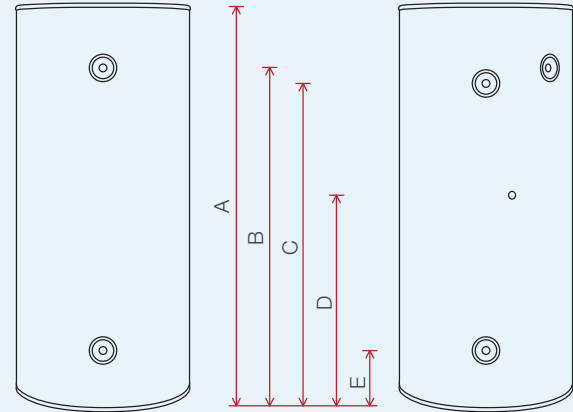
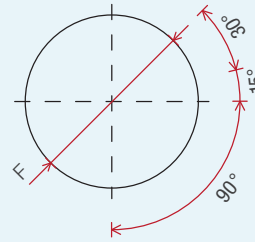

| Tank Model No: | SAN-43SSAQA | SAN-83SSAQA | SAN-119GLBK* |
|--|-------------|-------------|--------------|
| A Height | 38-1/8" | 68-7/8" | 63-3/5" |
| B Hot Water Outlet & PR Valve | 29-1/2" | 60-1/4" | 56" |
| C Heat Pump Return | 29-1/2" | 60-1/4" | 60-1/4" |
| D Sensor Port | 9-3/4" | 40-3/8" | 56" |
| E Cold Water Inlet / Cold Water to HP | 8-3/4" | 8-3/4" | 4" |
| F Diameter | 24-1/2" | 24-1/2" | 28" |
| Weight (lbs) | 88 lbs | 115 lbs | 345 lbs |
| Tank Capacity (gallons) | 43 gallons | 83 gallons | 119 gallons |
| Warranty | 15 years | 15 years | 10 years* |

Connection Sizes

| | |
|--------------------------------------|-------------------------------|
| Cold Water Inlet | 3/4" NPT (1 1/2" SAN-119GLBK) |
| Hot Water Outlet | 3/4" NPT (1 1/2" SAN-119GLBK) |
| Cold Water to Heat Pump | 3/4" NPT |
| Hot Water Return from Heat Pump | 3/4" NPT |
| Pressure Relief Valve Setting (Psig) | 125 Psig |

REV 02032021

*SAN-119GLBK tank is a glass-lined steel tank with a 10 year warranty.

Note: Materials and specifications are subject to change without notice.



For more information, please call **1-844-SANCO2** or email **info@eco2systemsllc.com**



Eco2 Systems LLC
 P.O. Box 1358, Walled Lake, MI 48390
 Phone : 1-844-726-3262 or 1-844-SANCO2
 E-mail : info@eco2systemsllc.com
 Website : www.eco2waterheater.com

Eco2 Dealer