

## GENERAL WIRING DIAGRAM

This diagram covers 8 systems. See instruction manual for individual diagrams.

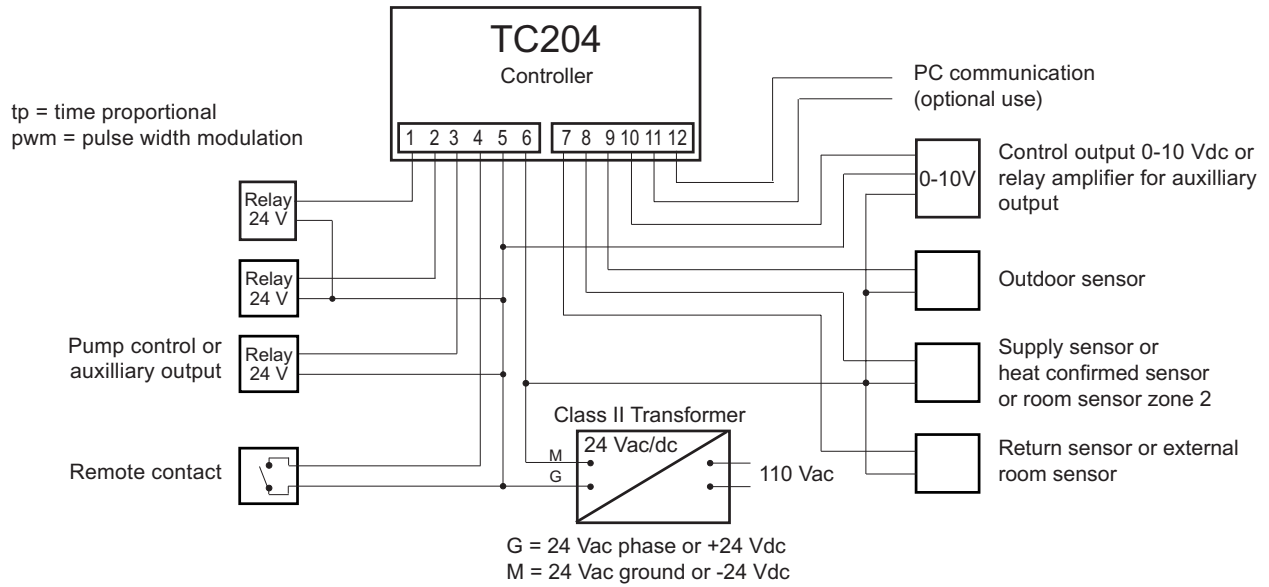

### TERMINALS

No. Function

- 1 Actuator 24 Vac heat increase or on-off / tp / pwm output 1
- 2 Actuator 24 Vac heat decrease or on-off / tp / pwm output 2
- 3 Time or outdoor temperature control of pump or auxilliary output
- 4 External contact input for remote control of operations mode
- 5 24 Vac phase or +24 Vdc
- 6 24 Vac common or -24 Vdc. Also ground for 0-10 Vdc output and sensors
- 7 Return sensor or external room sensor
- 8 Supply sensor or heat confirmed sensor or room sensor zone 2
- 9 Outdoor temperature sensor
- 10 Actuator or injection pump 0-10 Vdc or relay amplifier for auxilliary output
- 11 PC communication (optional use)
- 12 PC communication (optional use)

Some terminals have different functions depending on which controls program is being used. See instruction manual for details.

Available at:

**PEXHEAT.COM**